

University of Utah Metering Guideline – 2026

SUMMARY & PURPOSE

There is significant potential for inconsistency when installing, commissioning, & integrating meters. This guideline intends to provide clarification and set expectations for consistent, accurate & reliable outcomes. Site-level (also called building-level) meters are critical to University operations. They are used primarily for utility billing & benchmarking. Metering requirements may be found in many references including, but not limited to, the project-specific documentation (OPR, LEED, etc), University of Utah Design Requirements, & DFCM Design Requirements (including HPBS). The focus of this guideline is not to discuss every potential metering scenario or repeat each of the requirements; the intent is to be complimentary to other references, not redundant.

Where deviations from this guideline are proposed, communicate with the project manager and the Sustainability & Energy (S&E) group (energy@fm.utah.edu) for review and acceptance.

TABLE OF CONTENTS

SUMMARY & PURPOSE.....	1
COORDINATION OF WORK AND RESPONSIBLE PARTIES	2
DESIGN: SITE METERS & SUB METERS.....	3
DATA ARCHITECTURE & INTEGRATION	5
METERS FOR COMMON APPLICATIONS	6
METER INSTALLATION CONSIDERATIONS	8
COMMISSIONING (Cx)	9
APPENDIX A: ACQUISUITE INSTALLATION & INTEGRATION GUIDE	11
APPENDIX B: SKYSPARK INTEGRATION GUIDE	13

COORDINATION OF WORK AND RESPONSIBLE PARTIES

Table 1 is a list of tasks commonly associated with metering requirements. The list is not all inclusive and may show additional details that are not needed. The purpose of this list is *not* a preference or direction by the University of who is to perform the work, but simply to raise awareness of tasks that may need to be performed and to illustrate how many parties may be involved. The general contractor shall determine the work that is to be done and the responsible party.

Task	Responsible Party
Identifying meters in construction drawings, specifications. Details are adequate & basis of design specified.	Design team
Identifying suitable location for meters	Everyone! Lead by General Contractor
Piping provisions for flow meters & temp sensors (thermowells, taps)	Plumbing contractor
Provide & installing BTU meter	Controls contractor
Provide & install electrical meter	Electrical contractor
Provide & install water, gas, or steam meter	Plumbing contractor
Providing power source for meters, controllers, components	Electrical contractor
Installing DAS	Controls contractor
Wiring (Ethernet)	Communications contractor
Wiring (low voltage conductors)	Controls contractor
Insulation installed	Mechanical contractor
Programming DAS	Controls contractor
Integrating DAS into SkySpark	Controls contractor / CxP With support of UIT for verifying network settings
Commissioning & verification of accuracy, documentation	Meter manufacturer support, controls contractor, electrical contractor, CxP

Table 1: Common Metering Tasks

The best time to review meter locations in detail are during design or BIM review.

The amount of detail required to successfully install and commission meters and amount of coordination between trades is exceptionally high. For this reason, shop drawings are required for review by the University. These requirements shall be included in the specifications by the designer. These may be provided by the designer or delegated to the contractor. The shop drawings should show the schematics and physical layout details, including, but not limited to power & networking, plans, sections &/or isometrics.

DESIGN: SITE METERS & SUB METERS

Meters for every utility are required for each site (or building). Commercial meters meet this fundamental requirement. Redundant site meters installed by the contractor may be beneficial to automate utility tracking in more detail. The impact of redundant site meters should be discussed in with the Project Manager and S&E team in planning or during schematic design. When connecting to a University of Utah owned utility system, a site-meter must be included in the design and installed by the Contractor for every utility. Requirements for sub-meter applications should be specified in project specific documentation. Sub-meters shall also follow the guidance of this guideline, when required for a project. Utility metering for irrigation is commonly performed by a system specific to that function: WeatherTRAK by HydroPoint. Integration through this system is acceptable for irrigation metering.

Relying on multiple meters to determine total site usage is not allowed unless there is a physical separation of the utility entering the site or building. Some examples are below for common site-level utility scenarios.

Example: One meter measures flow on a domestic water line entering a building that provides water for occupants and irrigation for landscaping, which is submetered.

Conclusion: This configuration is not allowed because if one meter is broken or inaccurate, it has an impact on both utilities. Additionally, the domestic water total for the building must be calculated, which adds complexity. Even if there is only one physical line for water entering the building, each utility (DCW and Irrigation) need dedicated meters.

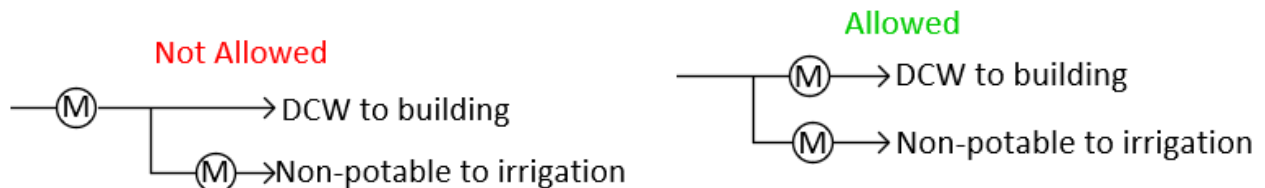

Example: There are two air handlers in a building that use chilled water. The design engineer wants to provide two meters: one for each air handler (AHU) to better understand demand for each air handler.

Conclusion: Although the thought and precision of energy use is appreciated, this metering configuration is not allowed. If submetering of each AHU is a requirement, one or more submeters (dashed lines) is required in addition to the building-level meter.

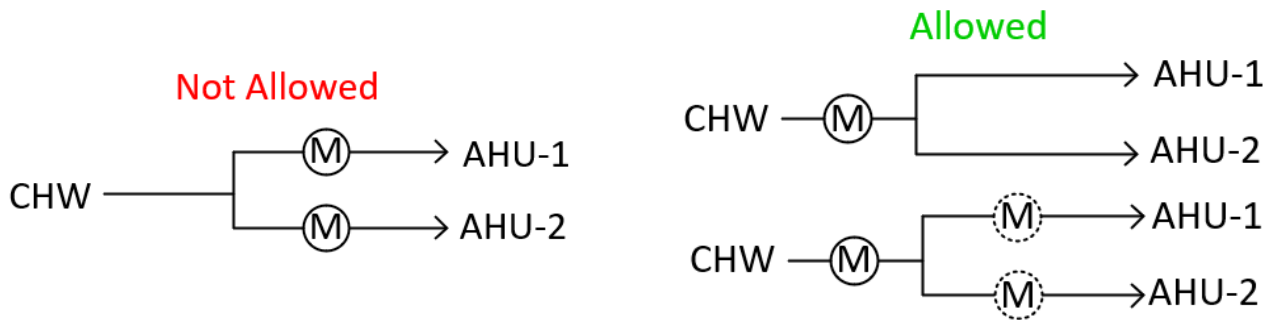

Example: A 160' tall building is constructed on a steep hillside. There are two domestic water lines entering the building: one on the first floor and one on the sixth floor. The loops are isolated.

Conclusion: If a meter can be located on a common domestic water line, that is preferred, but two independent meters are acceptable, because there are two independent physical lines to the building.

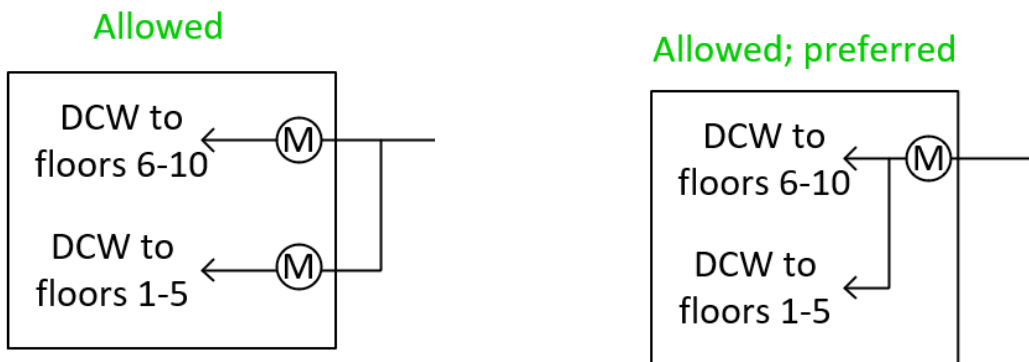

Example: Two buildings are fed by a condenser water plant. The buildings are pumped in a primary / secondary loop configuration.

Conclusion: Energy must be measured at each building. An energy meter at the plant does not satisfy the requirement of site metering. An additional plant meter may be required (dashed lines).

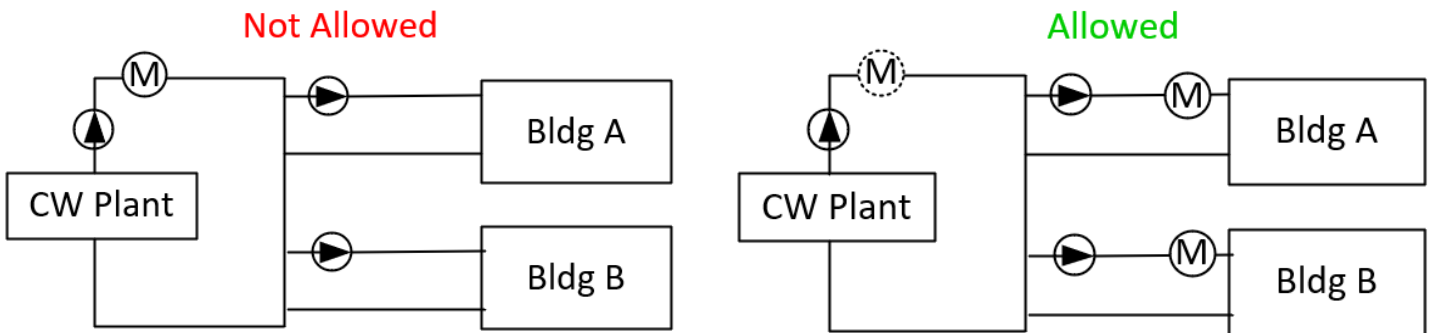

DATA ARCHITECTURE & INTEGRATION

All meters should be integrated in order to communicate with the University’s current Data Analytics platform (SkySpark) and provide the required points & trends. Utility information should be integrated into SkySpark through a DAS (Data Acquisition System, commonly referenced as an AcquiSuite). Although possible, integration of meters through the BAS (Building Automation System) is not preferred and should only be done with written approval by the Project Manager and S&E team. The current required architecture for data acquisition is shown in Figure 1, below.

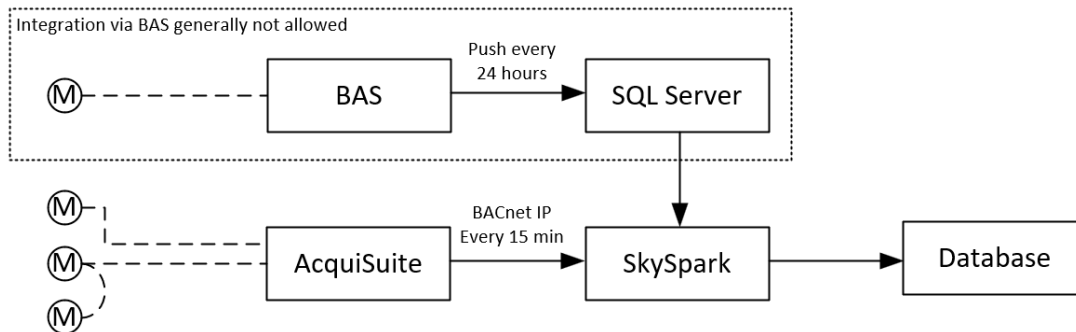

Figure 1: Energy Management Architecture

It is preferred to integrate site level meters via a serial connection when commercially available and justified economically. Pulse meters are limited to water meters & natural gas meters. Reference Table 2 for allowable sizes & capacities for allowable communication types for various applications.

METERS FOR COMMON APPLICATIONS

Table 2 is a list of meters often suitable for common applications. Selecting a meter from this list does not ensure it will work or is the best choice for every application. It is the responsibility of the designer and contractor (when delegated) to select appropriate models and configurations. This is not a sole sourced list of products. Acceptable products & manufacturers are specified by the designer & reviewed for general compliance.

Utility	Application	Basis of Design	Notes
Electricity	Main Service Panel	Electro Industries Shark 200	Serial output
	Main Service Panel	AccuEnergy Acuvim II	Serial output
	Main Service Panel & Sub-level	Obvius AcquiSuite Ally 48	Serial output
	Sub-level	Electro Industries Shark MP 200	Serial output
CHW & HW Energy Meter	Site-level & Sub-level	Onicon FT-3100 Inline Electromagnetic with System 10	PTFE construction may be required; check temperature, serial output.
	Site-level & Sub-level	Onicon FT-3400 Insertion Electromagnetic with System 10	Serial output
	Site-level & Sub-level	Onicon F-4300 Clamp-on Ultrasonic	BTU meter option. Serial output
	Sub-level	Belimo Thermal Energy Meter (or Valve)	Serial output
Water	≤1 1/2"	Badger Recordall Nutating Disc	Pulse output register
	2" - 6"	Micronics Ultrasonic U1000MKII	Serial output
	≥8"	Onicon FT-3100 Inline Electromagnetic	Serial output
	≥8"	Onicon F-4300 Clamp-on Ultrasonic	Serial output
Natural Gas	≤1000 CFH, ≤2 PSI	American Meter AC/AL Diaphragm	Pressure & temperature Compensated, pulse output.
	>1000 CFH, ≤10 PSI	American Meter RPM Rotary RTVP	Pressure & temperature Compensated, pulse output.
	>1000 CFH, ≤10 PSI	Onicon F5500 Thermal Mass Insertion Meter	Pressure & temperature Compensated, serial output.

Table 2: Possible Application & Product Table

Units

It is important to select a range of units and scaling that provides a balance of precision and reduces frequency of meter rollover. Meters should be specified such that a rollover occurs no more than once every two months. If physical meter reads are required for a period, rollovers require meter readers to assume rollovers and bring in a significant potential for error. Meters may need to be ordered with units selected or this may be configured during commissioning.

For example, a low volume makeup water meter that serves an isolated closed loop system should generally not have the same units or scaling as a high flow recirculating system. This is an important design consideration that needs to be addressed. Including these details in the equipment submittals or shop drawings will avoid confusion in the future when commissioning meters.

Communication Protocol Options

Historically, the only serial communication protocol on AcquiSuites was Modbus RTU. BACnet MS/TP is now an option for some models of AcquiSuites. It is more widely used for BAS systems and generally preferred over Modbus RTU. Connection over IP (BACnet IP or Modbus TCP) are also increasingly more common in the industry. These integration methods are allowed but are not commonly done. Troubleshooting network settings has historically been difficult; it is recommended this integration path is selected with caution with careful planning & coordination with UIT.

More important than the specific communication protocol(s) used is understanding device compatibility and understanding how they will work as a system & connect to the network.

METER INSTALLATION CONSIDERATIONS

Installed location is very important for meter accuracy and ease of use for staff. The correct product in a poor installation will have poor outcomes. Careful consideration must be given by the design & construction teams. Manufacturer's installation instructions should always be considered.

Based on University experience, the following installation considerations should be paid special attention:

- Meters should be installed indoors, not in vaults or confined spaces.
- Site level meters should generally be located close to the building entrance to reduce the possibility of any future connections bypassing the meter.
- Bollards should protect the metering skid if located adjacent to a sidewalk, road or location where damage may occur.
- Piping diameter may have to be modified to achieve acceptable operating conditions for minimum and maximum flow rates.
 - For liquid application, 5-30 diameters of straight piping may be required before and after the meter to achieve stated accuracy.
 - Gas applications may require even longer straight sections!
- Ensure the available space to install a meter and the type of meter provided meet the requirements in the construction documents and the manufacturer's installation instructions.
- Water meters (including domestic water, CHW, HTW) may not be installed in a vertical orientation without prior approval by S&E.
- All meters need to be located in an area where they can be easily maintained, repaired and replaced.
- All meters shall have a bypass line for continued operation when a meter needs to be temporarily taken out of service.
- A physical meter reading display (register) needs to be on the meter where it can be easily read by any height of technician from the ground for verification of data, troubleshooting and commissioning. If this is not possible, provide a remote display. Meters require field verification for billing purposes.
- When replacing a meter, it is preferable to remove all existing components. Modifications should be communicated to S&E to update utility schematics and provide information needed for correct integration.
- Install shorting block for electrical meters when the current transformer used may produce a high voltage.
- Install a switch next to the meter to allow service disconnection from line voltage. Switch does not have to be lockable.

Contractors may always request a pre-installation inspection by University of Utah staff to ensure the installation parameters are acceptable. Please allow sufficient time between the inspection and planned installation date if consultation with third party experts is required.

COMMISSIONING (Cx)

Cx scope shall include meter integration quality checks, including verification of correctly installed data points, naming, taxonomy, trends, and functional meter installation and operation qualification. The University is expecting the following documentation standards, per meter, of a successful outcome:

Installation Verification

- Identify meter being commissioned is as specified in design documents (make, model, S/N, dual channel, etc)
- Identify proper installation per manufacturer's instructions:
 - Orientation.
 - Many insertion probes must be installed within a specific angle in piping
 - Pipe size, insertion depth
 - Fluid or medium being measured is accurate to the meter calibration setup
 - Sensors in right place and tied in to correct I/O, flow meter, etc
 - Adequate pipe-lengths and distance from bends and obstructions of proper reading
 - Correct power is supplied to meter
 - Sensors installed per manufacturer recommendations and with proper coatings applied when applicable
 - Others, as applicable
- Identify and provide documents (i.e. user manual, O&M manuals, drawings, 1-lines)
- Verify components have supply power & function per manual
- Verify PMs are setup and spare parts are identified for longevity of the system

Operation Verification

- Display screen and button functionality testing
- Unit of Measurement (UOM) verification
 - Confirm meter display and integrated value match
- Set-up points and trends appropriately. Reference DFCM HPBS, Appendix F
 - Exception: Do not use tag '*hisTotalized*' in SkySpark.
- Verify communication with AcquiSuite or BAS (if approved), and the current Metering/Data Analytics platform (SkySpark) for accurate and matching readings.
- Provide meter "start up" report prior at least one month prior to substantial completion.
 - Should include meter information (configuration of units, serial number, model number, network info, CT ratio, PT info, etc).
 - Verify meter reading against a calibrated device (NEBB or T&B certified) and document result for installation/operation verification

Substantial Completion Pass-Off

- At Substantial Completion, building consumption must be tracked by the University (note: frequently billing is required). The Contractor shall confirm meter readings and the date of pass-off for each utility.
 - If a new commercial meter was installed, account information must be forwarded to S&E (energy@fm.utah.edu)
- Contractor shall include S&E in MEP walk-through to review meter locations and piping – *S&E is available to review installation prior to substantial completion for a preliminary review*

Documentation

Metering should not be considered complete until all building level and relevant sub-meters are fully integrated to the Metering/Data Analytics platform with all points, units of measures (UoM), trends, and tagging matching the details provided in this standard and appendices. Document as-built conditions and update the shop drawings to be integrated in the record documents.

Once passed off to S&E, S&E will assign asset numbers and track all meters in the asset management software: CMS.

APPENDIX A: INSTALLATION & INTEGRATION GUIDE

All RS-485 communication wires shall have 4 conductors and a shielded ground. The two “spare” conductors can sometimes be used to correct wiring configurations and will prevent pulling a new cable.

In System setup, the AcquiSuite name will be FM-AQx-building #. The “x” will be the sequential number of AcquiSuites. Provide a room number in the location. The description is the serial number (also the MAC number).

System Setup

AcquiSuite Name:	FM-AQ1-0048
AcquiSuite Location:	Rm 1128
AcquiSuite Description:	001EC600283C
AcquiSuite Administrative Contact:	
AcquiSuite Login Screen Information:	Name + Location ▼

Under the BACnet tab in in AcquiSuite configuration, assign custom entries to multiple fields. Contact the UofU Controls team @ (801) 585-1546. Provide the application, building #, number of devices & addresses. They will assign a virtual network number & a BACnet object ID. The BACnet Base object name will be the building number followed by the sequential number of Acquisuites. If there are 2 AcquiSuites in building 48, they would be “0048-AQ1, 0048-AQ2”.

BACnet base object name:	<input type="radio"/> Auto: AcquiSuite_12_179	<input checked="" type="radio"/> Custom: 0048-AQ1
BACnet base object ID:	<input type="radio"/> Auto: 179000	<input checked="" type="radio"/> Custom: 291500 <small>(0-4194302; use Discover to choose unused ID).</small>
Virtual network number:	<input type="radio"/> Auto: 58461	<input checked="" type="radio"/> Custom: 4014 <small>(1-65534; use Discover to choose unused net number).</small>

Figure 1: Examples of custom entries. Do not use the values above; they will need to be assigned by the UofU.

Ensure meters can be shared via BACnet. Do NOT set this value to “None (Gateway disabled)”

Meters shared via BACnet:	All ▼	<small>Select “None” if unneeded; sharing meters via BACnet doubles RAM-usage/meter.</small>
---------------------------	-------	--

If using Modbus, ensure the baud rate is compatible with all devices. Do not select more than one baud rate.



Modbus Setup

Modbus TCP Access:	<input type="text" value="Allow ModbusTCP access from local subnet only"/>
	<input type="checkbox"/> 9600 (default) <input type="checkbox"/> 19200 <input type="checkbox"/> 38400 <input checked="" type="checkbox"/> 57600 <input type="checkbox"/> 115200
Modbus RS/485 baud rate:	<input type="text" value="None (default)"/>
Modbus RS/485 Parity:	<input type="text" value="One (default)"/>
Modbus RS/485 Stopbit:	<input type="text" value="200ms (default)"/>
Modbus RS/485 timeout:	<input type="text" value="None (default)"/>
Modbus RS/485 debug information:	<input type="checkbox"/> enable <input type="checkbox"/> enable

There are a limited number of BACnet object ID's available. The AcquiSuite is the base object number. Connected device addresses will add the address to base object number. If the AcquiSuite has a base object ID of 291500, the Power Meter on panel MDL1 would have the object ID of 291502. All internal I/O's are used are automatically assigned address 250. Be aware that if they are used, this object ID should be an outlier from others grouped with smaller address numbers.

When importing devices into an AcquiSuite, the name & Purpose format shall be the application (Example: CHW), a description of the service (Example: Chilled Beam Loop) and the meter number (contact S&E for this to be assigned). If a meter has multiple channels, note which application & meter number is assigned to each channel.

Device List

Device	Status	Name and Purpose	Type
 002	Ok	Power 120/208v MDL1 (321266)	Electro Industries Shark 200
 003	Ok	Power 277/480v MDH1 (321265)	Electro Industries Shark 200
 250	Ok	Internal I/O	Obvius, A8812, Internal I/O
Add		Rename all devices	List all supported devices

APPENDIX B: SKYSPARK INTEGRATION GUIDE

Reference DFCM HPBS requirements (HPBS, Appendix F for list of nomenclature & tagging requirements) As best practice, the current versions of these should be requested for each project to ensure current versions are used. One exception the university takes to Appendix F tagging requirements is the tag *hisTotalized*. This tag should not be used.

There are multiple projects in SkySpark; they are separated by building number. Ensure the points are integrate in the correct range of buildings.

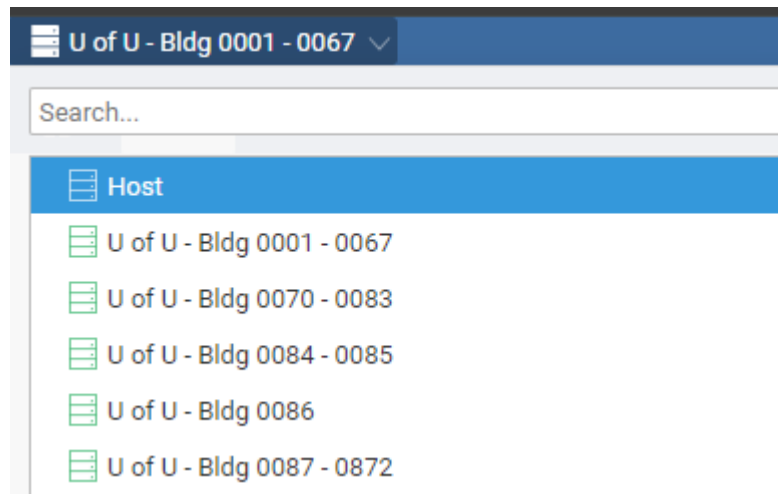

The 'id' consists of the AcquiSuite BACnet base object name, the meter description & number. Ensure these match in the AcquiSuite & SkySpark.

id	connStatus	connState	uri	aimAsset
0048-AQ1 Power 120/208v MDL1 (321266)	✓ Ok	● Open	bacnet://10.88.12.179/291502?dnet=4014&dadr=b30c2802bac0	321266

Create (or add to existing) Meters folder. This will be under the 'Global' folder & 'Meters' grouping.

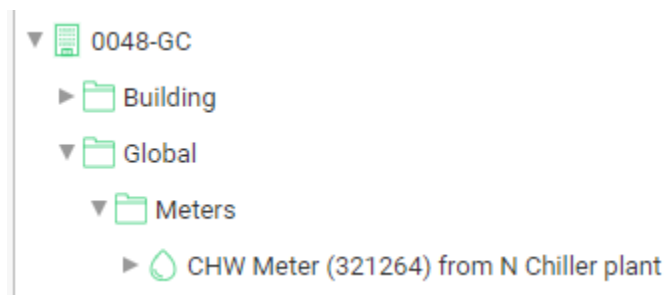

Tagging Summary:

Much of the information needed for tagging is to be provided by S&E. Confirm with S&E what tags should be used and info needed for tagging.

navName (string): Describes the type of meter and relevant description of what it serves. Include the word “meter” in the *navName* tag. The pom number should be in parentheses.

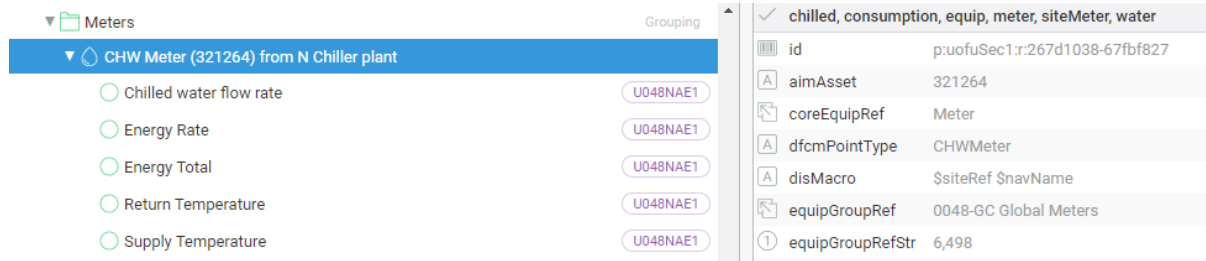

Grouping	Value
chilled, consumption, equip, meter, siteMeter, water	
id	p:uofuSec1.r:267d1038-67fb827
aimAsset	321264
coreEquipRef	Meter
dfcmPointType	CHWMeter
disMacro	\$siteRef \$navName
equipGroupRef	0048-GC Global Meters
equipGroupRefStr	6,498

pom (string): 12 digits. See below for detailed description. This number will be assigned/provided by the S&E team.

pomID (string): This is the same as the pom, but with an additional designation that shows the

meter: All meters should have this tag.

coreEquipRef: Meter

meterScope:

siteMeter: used if meter is used to calculate building utility consumption.

submeter: used if meter is NOT used to calculate building utility consumption.

billable: Used if consumption is billed to an external account.

monthlyReading: tied to points with totalized energy. Do not apply to meters.

inactive: Meters are no longer needed. *pom* tag will be removed. *monthlyReading* tag will be removed.

broken: meter is physically present, but not working. Reads are not possible in the field. Estimation is used exclusively. *monthlyReading* tag will be removed. *pom* tag will remain.

integrationErr: meter is working & field reads seem correct, but data is not transferred to SkySpark.

dataErr: data appears to be integrated correctly, but still appears suspicious.

manualRead: meter is present & working for field reads, but integration is not possible (new meter needed or communication module needed).

missing: a meter is not provided for a utility at a building (or site). One should be installed. A generic utility meter should be created in SkySpark. *pom* or *monthlyReading* tags will not be used until is installed & verified to be working.

comMeter (string): commercial meter/account associated with this meter

brokenDate (date): date meter stopped working. If unknown, but date meter was identified as broken.

brokenNotes (string): Use to help convey information regarding meter status to others.

chwRateCalc / *htwRateCalc* – used to identify meters used to calculate utility rates.

pom Tag Nomenclature

